



Product Data Sheet

SlimLane 940

Pedestrian Access Control Solution PS-PBAS-Slimlane

The SlimLane 940 double swing door security entrance lane offers a high bidirectional throughput and uncompromising security.

With its transparent, elegant design and **minimal footprint**, the SlimLane 940 is designed to integrate perfectly into any architectural style.

Equipped with high processing capacity and an exclusive detection system, the SlimLane 940 guarantees accurate user tracking and prevents any unauthorised use.

The SlimLane 940 is a modular product that can be installed as a single or a multi-lane array and can also be combined with the SlimLane 950 wide lane model.

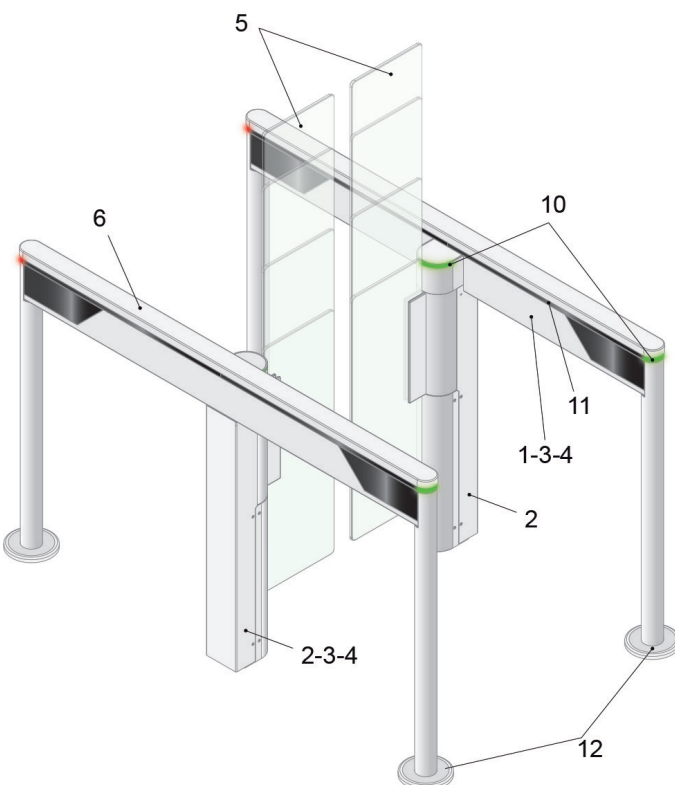

1. Handrail frame: steel beam with RoHS anti-corrosion zinc plating treatment and stainless steel posts. The handrail includes photoelectric cells for user detection and the logic control board.
2. Self-supporting kinematic steel frame with RoHS anti-corrosion zinc plating treatment. The frame contains the electro-mechanical drive assembly for the swinging obstacle and the electronic control boards.
3. Brushed #4 AISI 304L stainless steel housing.
4. Brushed #4 AISI 304L stainless steel panels fastened to the frame for access to the internal components.
5. Clear, 10 mm thick tempered monolithic glass obstacles, swinging in the direction of user passage.
6. Brushed #4 AISI 304L stainless steel top cover.
7. Electromechanical drive units each consisting of:
 - A DC permanent magnet motor with epicyclic gearbox.
 - A controller providing progressive accelerations and decelerations of the obstacle, for smooth movement and enhanced user safety.
 - A geared electromagnetic brake for locking of obstacles in the event of forced entry attempts.
 - A sensor controlling the obstacle position.
 - SECURI-SAFE standard operating mode: electromechanical lock of the obstacles in case of forced entry attempt in any passage directions.
8. AS1167 logic control board, equipped with ARM technology and the Linux operating system, ensuring advanced traffic management. An embedded Web server, accessible by a simple web browser, offering an interface for the configuration of functional gate parameters as well as a complete diagnostic and maintenance tool.
9. Transfer of information from XML-RPC protocol through an Ethernet or USB interface, and dry contacts: passage authorisation, passage information, reader locking, fraud, equipment failure, ...
10. Orientation and function pictograms indicating gate and passage status to the user.
11. Proprietary DIRAS detection system, consisting of a high-density matrix of infrared transmitter/receiver photocells beams. It follows users progression through the gate as well as ensuring their safety during opening / closing of the obstacles.
12. Finishing plate for post.

STANDARD TECHNICAL CHARACTERISTICS (per lane)

Electrical supply	Single phase 240 VAC (+/-10%) - 5A - 50 Hz + Ground
Power consumption	Standby: 50 W Cycle: 170 W Maximum: 300 W
Motors (x2)	24 VDC – nominal output power 93 W
Passageway (L)	600 mm 550 mm < L < 725 mm (min/max)
Min opening or closing times	0,7 s (Depending on the access control system reactivity and the speed of users)
Ambient operating Temperature	0 à +50°C
Ambient relative humidity in operation	< 95%, no condensation
MCBF	5,000,000 mean cycles between failures, with recommended maintenance.
Sound level	55 dB
Weight	62 kg (per left/right unit) 91 kg (per intermediate unit)
IP	40
CE	Conforms to European standards
5 Year Warranty*	

OPTIONS

1. EGRESS operating mode: obstacles open in the direction of egress by a simple push.
2. Battery backup for automatic opening in case of power failure and obstacles locking mechanism in egress direction.
3. Clear, 10 mm thick tempered glass side panels.
4. Mobile leaf height: 1200, 1500 or 1700 mm.
5. Enhanced electronic protection and 'trolley' protection cells kit (A and B directions).
6. Transparent glass side wall with enhanced electronic protection and 'trolley' protection cells kit (A and B directions).
7. Reader post.
8. Standard support bracket for external reader integration.
9. Customised self-adhesive logo on obstacles.
10. Black handrail cover.
11. Fixing frame to embed in the concrete, to fix the equipment and pass the electric cables.
12. Monitoring panel.
13. Connectivity kit for Ethernet connection of one or more lanes to the network.

Note: For restrictions on options, refer to the price list.



PRECAUTIONS FOR USE

- For security reasons, children (user smaller than 1 m tall for mobile obstacles of 900 mm height and smaller than 1,3 m for mobile obstacles from 1200 mm to 1700 mm height) must be supervised by an adult at all times when in the vicinity of the unit and during passage through the lane.
- A child must absolutely precede the accompanying adult when lane passage is required.
- If habitual use by children is anticipated, Automatic Systems recommends the addition of all options required to optimize the level of protection.

STANDARD DIMENSIONS (mm)

